

IPSWS-SM

Surface-Mount IP Speaker

Overview

Broadcast announcements in auditoriums and large spaces with the PoE Surface-Mount IP Speaker.

The IPSWS-SM easily integrates with VoIP phone systems, approved 3rd party software, and includes ClockWise Campus software with purchase.

Description



AUDIO

8" high-efficiency speaker.
Audio coverage up to
600ft².



MICROPHONE

Hands-free two-way
intercom.



PERIPHERAL INTEGRATION

Connect a call button.



SOFTWARE

ClockWise Campus
software included.
Compatible with approved
third-party software.



SIP INTEGRATION

SIP-enabled.
Easily interfaces with
VoIP / SIP phone systems.

Solutions	Additional Features	Compatible Peripherals
<ul style="list-style-type: none"> • Paging • Intercom • Bell scheduling • Code alerts • Emergency notification • Music streaming 	<ul style="list-style-type: none"> • Built-in web server • Full multicast and broadcast support • Requires Cat5 or Cat6 cable • Back enclosure is included 	<p>Call Button Kit with Mic</p> <ul style="list-style-type: none"> • BTN-KIT-MIC-ND

Dimensions

(Dimensions are subject to change)

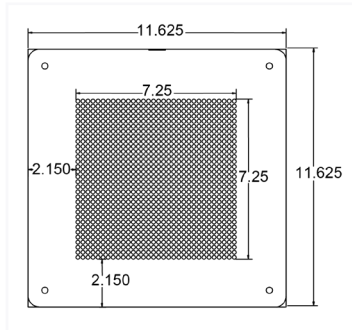

Front

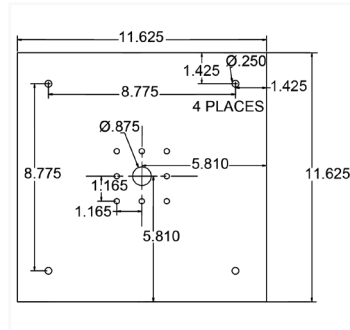

Back

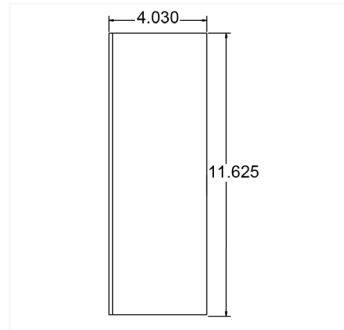

Side

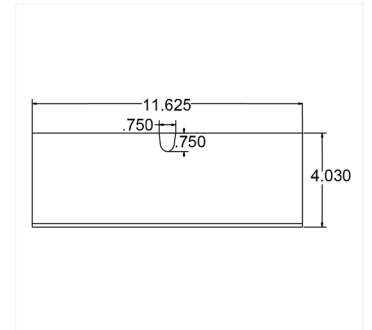

Top

Specifications

Due to continual product development, specifications are subject to change without notice.

Power Input	PoE (IEEE802.3af) 15.4 W or PoE+ (IEEE802.3at) 30.0 W
Ethernet I/F	10/100 Mbps
Speaker Size	8"
Audio Power	8 W / 16 W
Frequency Response	60 Hz - 17 kHz
Audio Payload Types	G711, A-law and μ -law
Average Sensitivity	95dB, 1W / 1 M
Supported Protocols	SIP, IPv4, IPv6, 802.1X, HTTP, SLP, TFTP, NTP, SNMPV1 & SNMPV2c, DHCP, IGMP, ICMP, TCP/IP, LLDP-MED, UDP, MDNS & MDNS-SD
General Purpose Interface	2 GPI: 1 via RJ-11, 1 via Cable Harness
Material	Wiremold combination 5700 knockout for 500 and 700 series raceways
Operating Temperature	14° TO 122° F (-10° TO 50° C)
Dimensions	11.63" W x 11.63" H x 4.16" D
Weight	9 lbs (4.1 kg)
Warranty	2 Year Limited

